

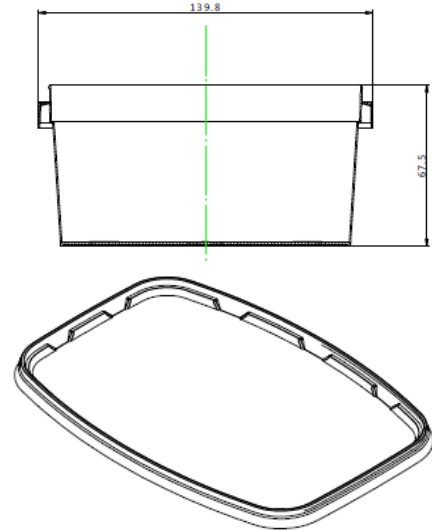

Shalam Packaging Group

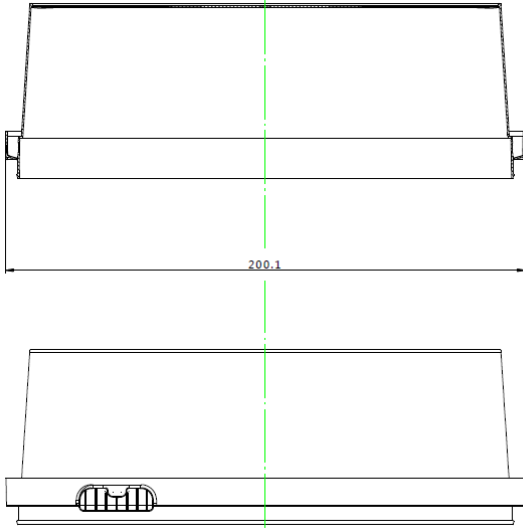

1.25 LITRE COFFIN TUB

ITEM CODE:

Lid:

Tamper Evident

MATERIAL

Food Grade Polypropylene Co-Polymer

COLOUR

Natural or clear – a range of colours are available on request

DECORATION

IML Available on Lid and Base

BRIM VOLUME

1.39 Litres

WEIGHT

Container: 40g (+/- 2g)

Lid: 17g (+/- 1g)

QUANTITY (EMPTY)

Container: 1,890 per pallet (1000mm x 1200mm)

Lid: 8,820 per pallet

STACKING (EMPTY)

Container: 3 pallets high

Lid: in pallet box 3 high

FILLING (Based on product density 1.4 air temperature 20°C)

296 per pallet (37 per layer x 8 high)

This is equivalent to a maximum weight of 13kg on the lower tub
700mm maximum pallet height

FILL TEMPERATURE

Max 70°C (avoid prolonged exposure over 40°C and below -25°C)

Polymer blend can be adjusted to suit other temperatures.

COMPATIBILITY

It is the responsibility of our customers to ensure their product is compatible with the container. Trials can be carried out by Shalam on request

All details correct at the time of printing. Please contact us for additional technical, sales and order assistance.